

Safe&StopVNA

The only collision avoidance system specifically designed for **VNA trucks**



Safety by any means



SAFETY IMPROVEMENT SYSTEMS



SAFETY BY ANY MEANS



Our commitment

Forklifts are the most dangerous vehicle in industrial environment: recent studies* confirm that 57% of accidents involving them caused fatalities or serious injuries, mainly to the detriment of people not driving the vehicle.

2/3 of forklift accidents cause the **death or injury** of people who are **not** driving the vehicle.

For over 10 years **SIS safety** has been committed to the prevention of workplace accidents with forklifts, with **over 6,000 active installations**, several saved lives and a commitment which continues and wants to grow in the future.

SIS safety devices product range is the result of one of the areas of specialization of **Cy.Pag. S.p.A.**, **one of the most important companies in the industrial automation sector.**

Solid foundations in the development of sensors and electronic design, a close-knit team of highly skilled engineers and the appeal to the most advanced technology have allowed rapid growth of the company, which **has established itself as a reliable partner for companies and brands of international level** bringing a significant contribution of innovation in the approach to Safety.

Track record

6,000+ devices installed worldwide.

* INAIL data



Safe&StopVNA

✓ REACTIVE

✓ COMPACT

✓ VERSATILE



The first **anti-collision system for VNA forklifts** providing optimized installation and maintenance costs, which is can be **autonomously managed with different functional modes*** (stop, slowdown, alarm) and which also **operates outside of aisle***, with Solid State Lidar technology.

It's a modular system that **makes immediate customization possible.**



SOLID STATE LIDAR SYSTEM
The most evolved ever

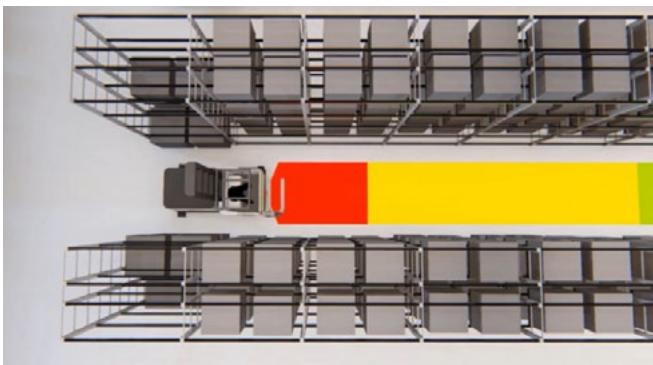

The forklift is in the aisle.



The forklift approaches a person or an object.



Safe&StopVNA provides acoustic and visual alerts while approaching an obstacle and, if configured as active*, slows or even stops the truck.

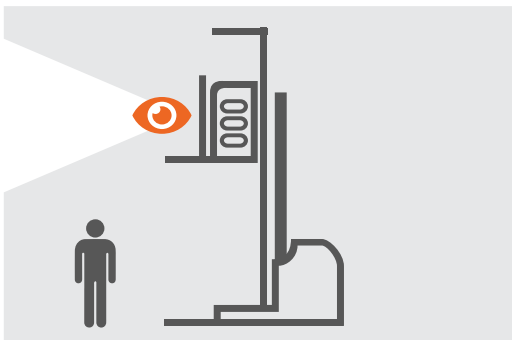

REDUCED VISIBILITY

The shape of the mast and the mobility of the cabin considerably limit the view in both directions.

We need aid systems going beyond the perceptions of the operator.

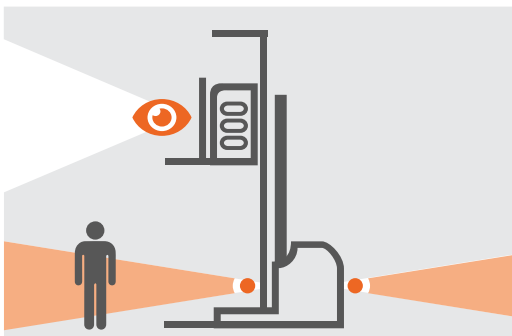

BENEFITS/PERKS

Safe&StopVNA signals every obstacle and/or person on the path of the forklift. This means:

- reduce the risk of accidents and prevent related consequences
- combine two technological eyes with the driver's ones.

SOLID STATE LIDAR

This technology provides **immediate analysis capabilities**.
No delay in the detection of obstacles or people suddenly appearing.
Safe&StopVNA is based on the only specifically designed sensor.

COMPATIBILITY*

Can be installed on **most VNA trucks**.

3 LEVELS OF SETTING*

Slowdown + Stop
Slowdown only
Visual/Acoustic alert only

DEDICATED SUPPORT

Our technical team is **always ready to support you for installation and settings customization**.

SHIPPING AROUND THE WORLD

We reach and protect **every type of company in any part of the world**.



GOALS

| 6 |

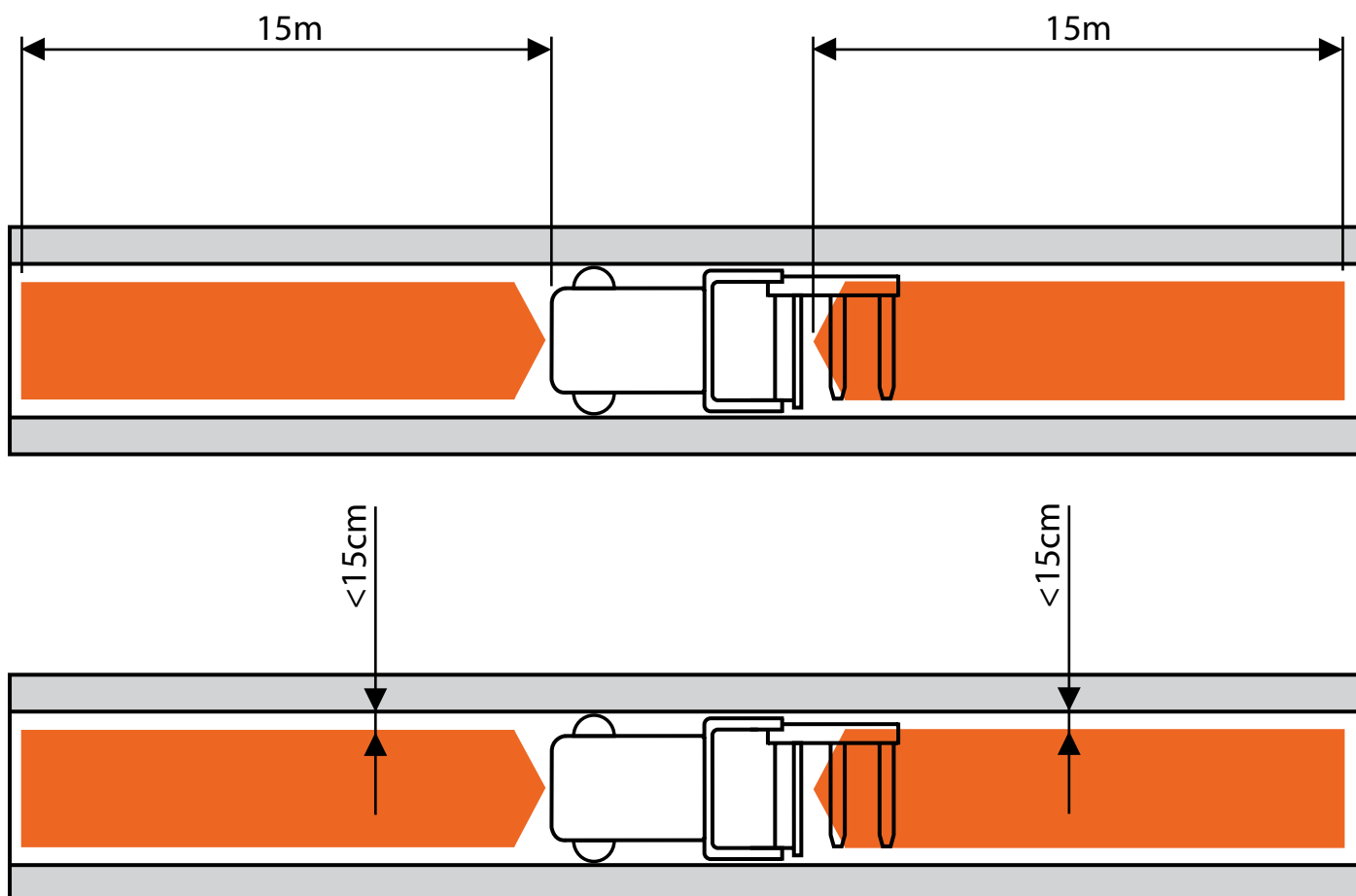

RADICAL REDUCTION OF ACCIDENTS AND RISKS

From damage caused by VNA trucks, due to the **lack of visibility**, especially operating with raised cabin.

INSTALLATION AND PERSONALIZATION

With **technical support** both for mounting and functional implementation.

PHONE AND VIDEO SUPPORT

For installation, setting and parameters customization.

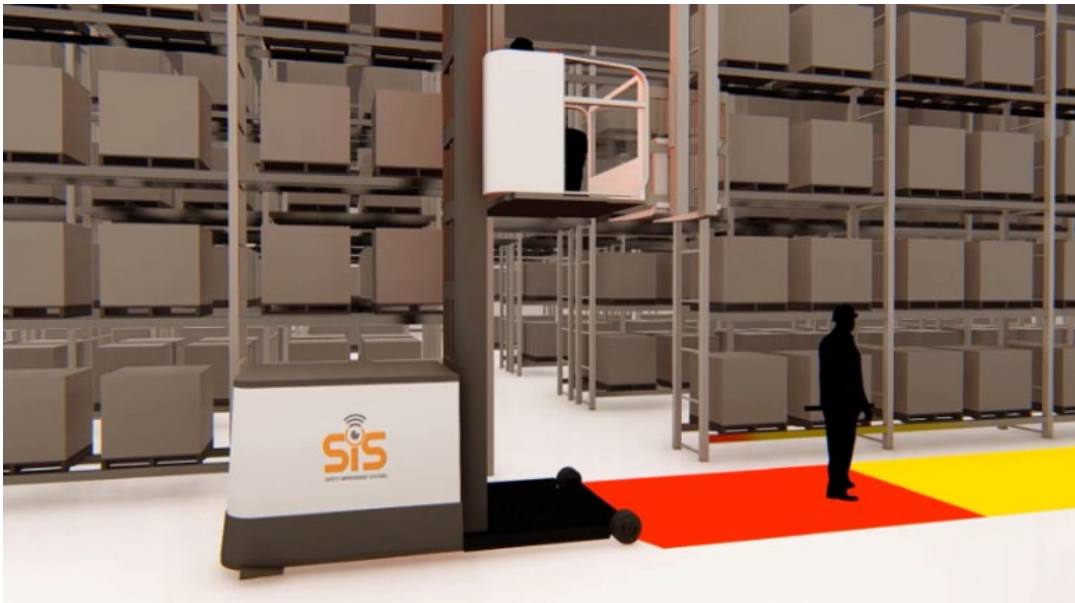

ACTIVE SAFETY*

On the speed of the vehicle, with the possibility of further **customization** in a second time.



PASSIVE SAFETY (VISUAL/ACOUSTIC)

Audible/visual signal, with the possibility of further customization.

Front

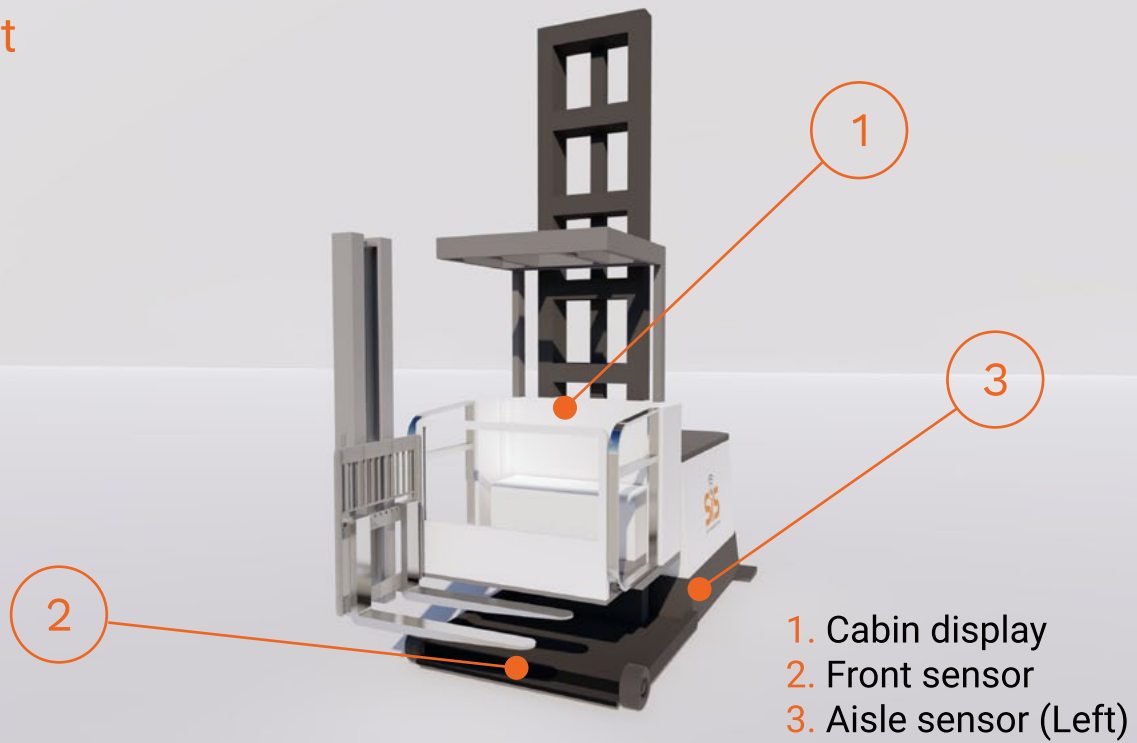

Back

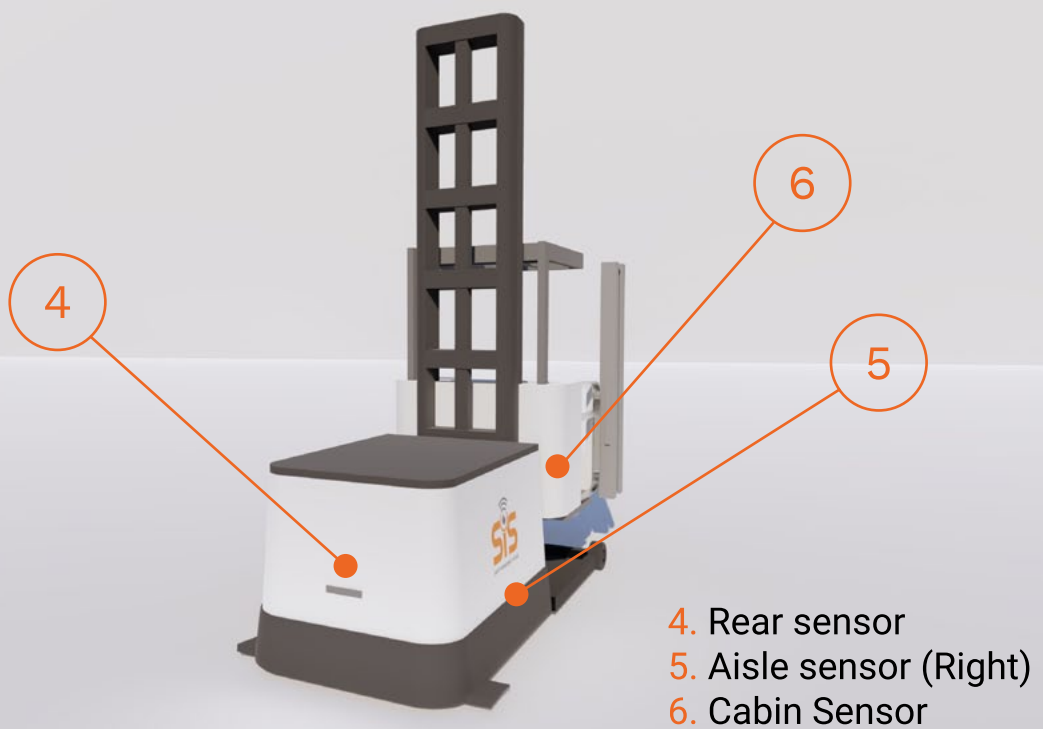

1. Active level with optionals*

Adaptive system self-adapting to environmental changes **inside or outside the aisle**. These trucks were born to work in narrow lanes, but in the event that they have to exit, the system automatically adapts to the new environment, switching to a different detection range.

2. Active level*

With **progressive slowdown** of the truck (even stopping the truck if required).

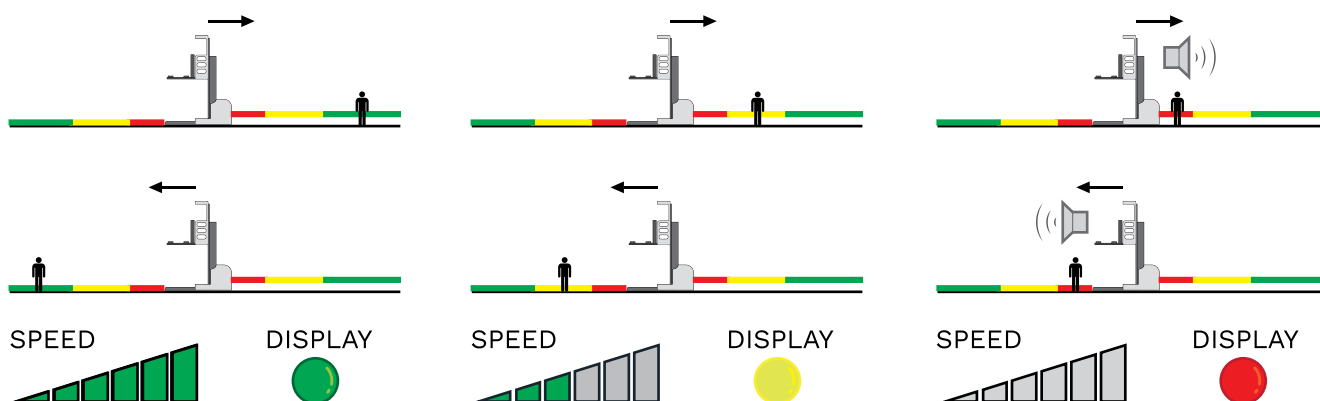

3. Passive level

Visual/acoustic signal only.

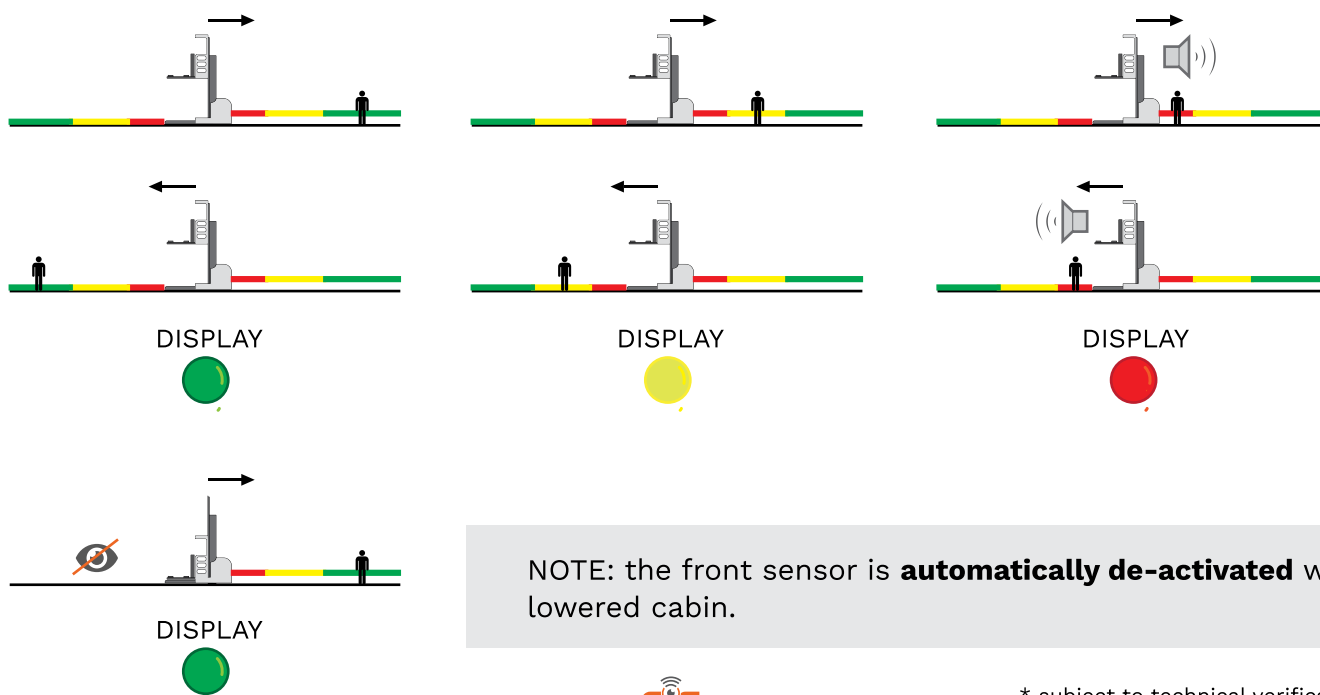

NOTE: the front sensor is **automatically de-activated** with lowered cabin.

SIS-Safety employs **Solid State LiDAR** technology, more reliable about weaving and dead zones if compared to classic laser scanners.

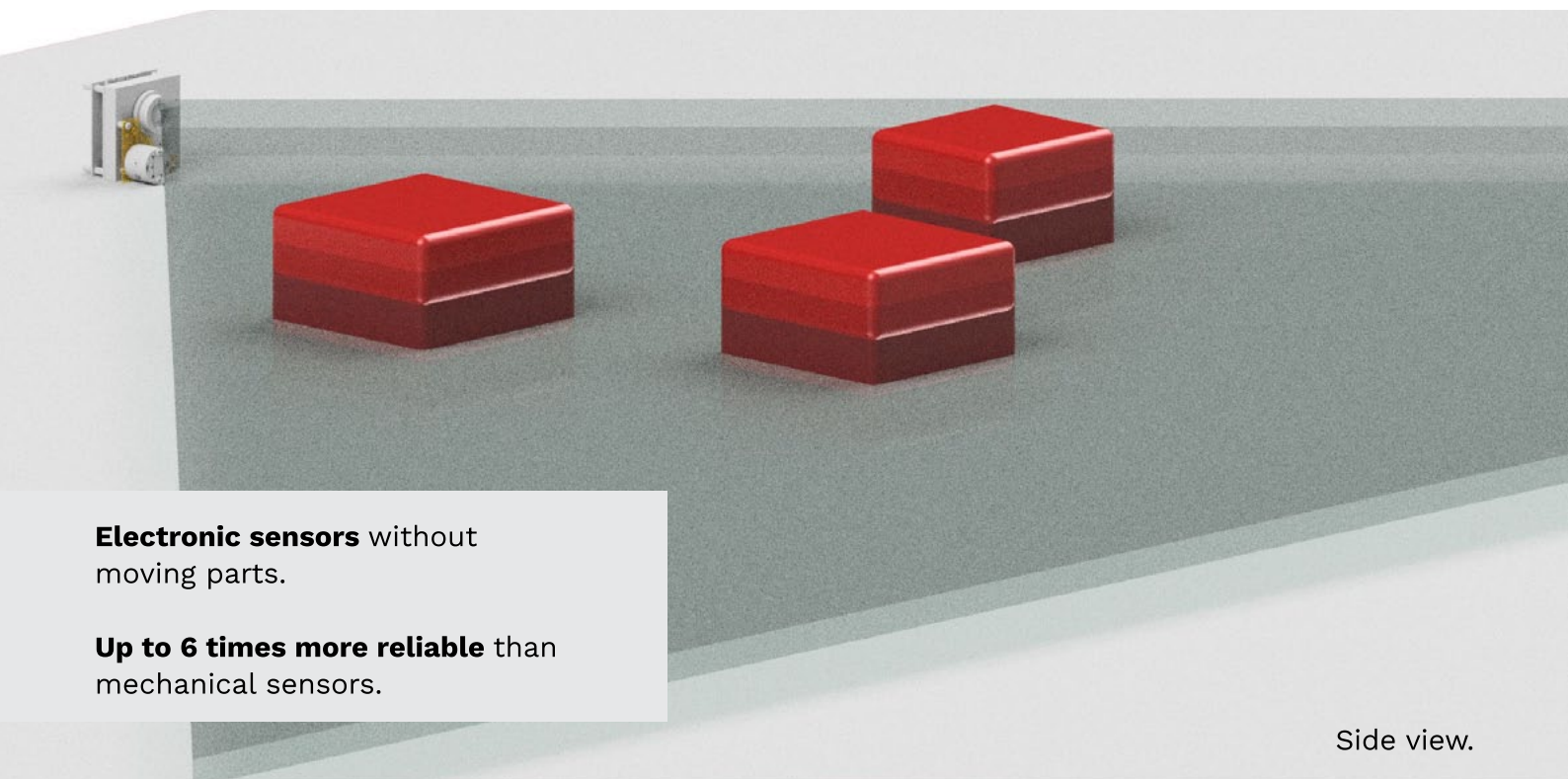

Electronic sensors without moving parts.

Up to 6 times more reliable than mechanical sensors.

Side view.

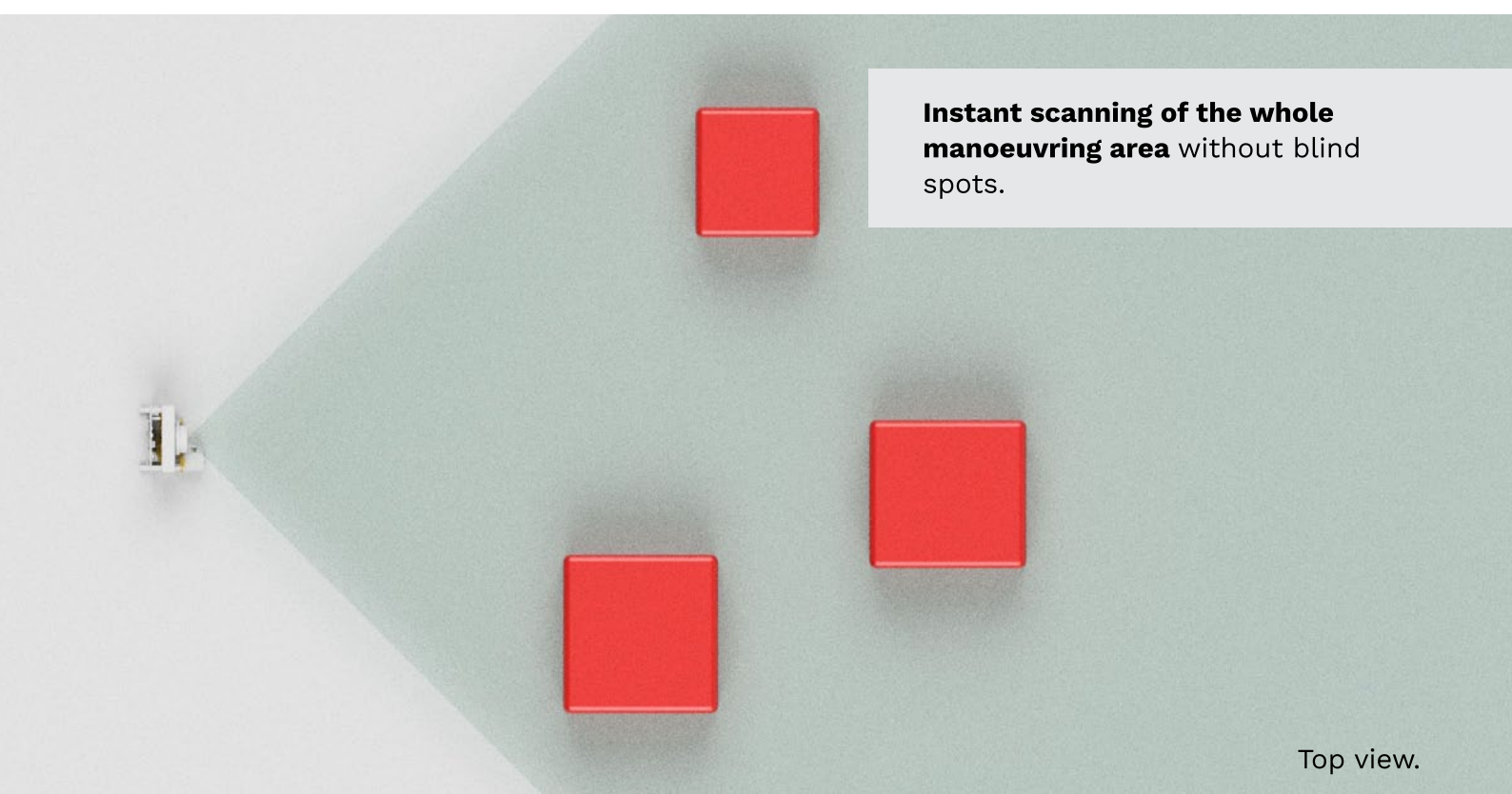

Instant scanning of the whole manoeuvring area without blind spots.

Top view.

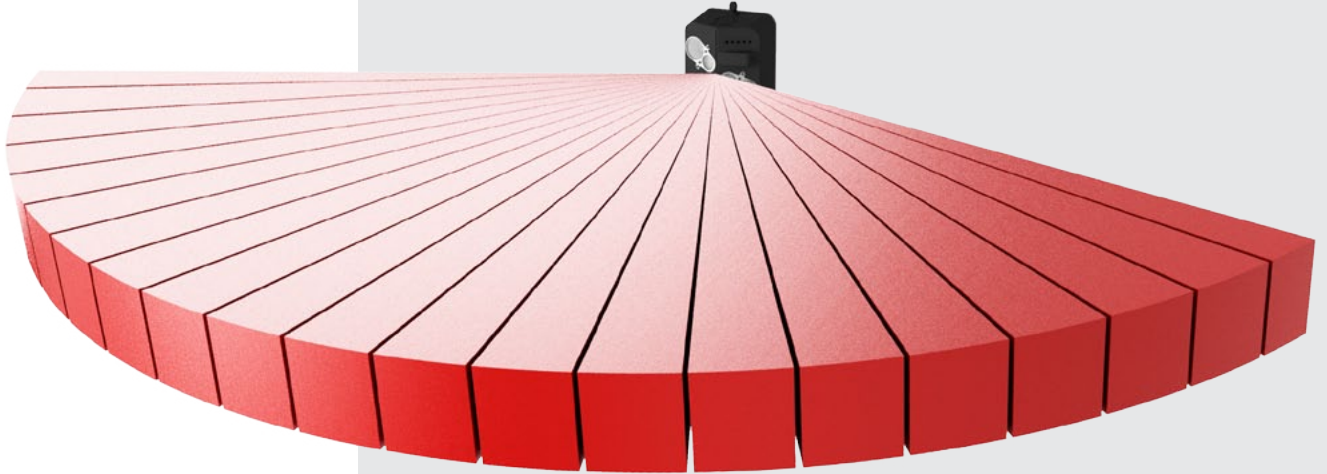

VIBRATION RESISTANCE

Due to the **absence** of moving mechanical parts.

HIGH SENSITIVITY

With any ambient lighting condition.

RELIABILITY

Adverse conditions: vibration, shock, temperature, etc.

ACCURATE DETECTION

32 detection segments without blind spots.

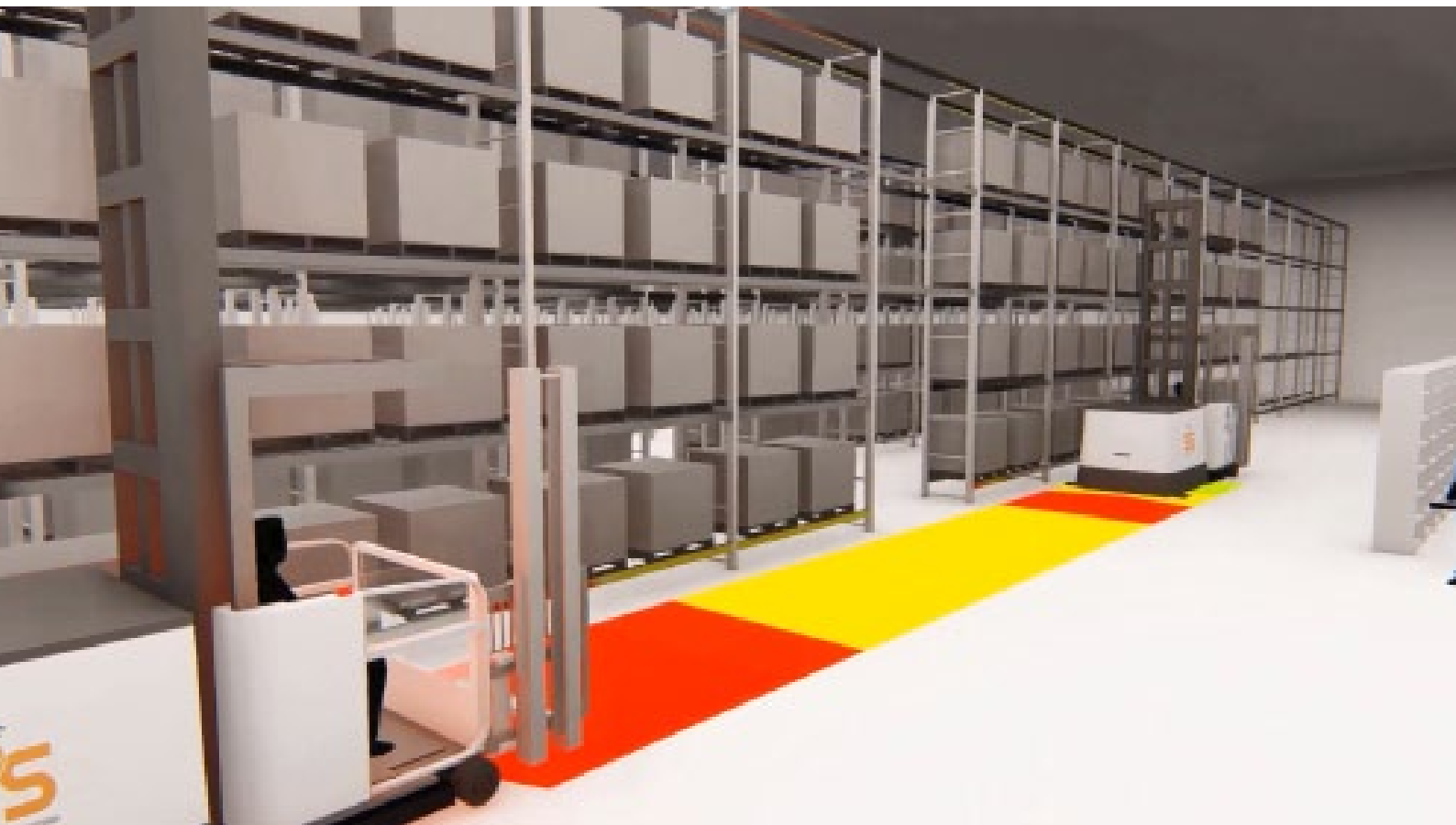

DETECTS PEDESTRIANS AND OBJECTS

It immediately signals obstacles, **warning** the driver through visual/acoustic alert, or by actively intervening on the truck.

OPERATES OUT OF THE AISLE

The system has not to be de-activated outside aisles. It will automatically adapt detection range and active functions* to new condition.

LEAVING THE AISLE

Safe&StopVNA is the only system self-adapting detection inside and outside the aisle, by remaining fully functional.

Entering in the aisle the system **will automatically switch** to related specific settings, without need of manual operations.

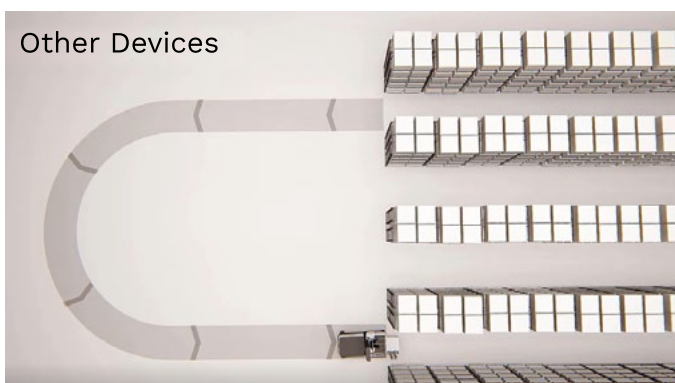
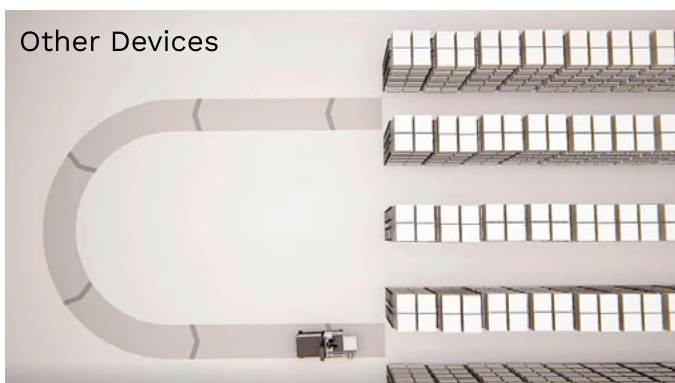
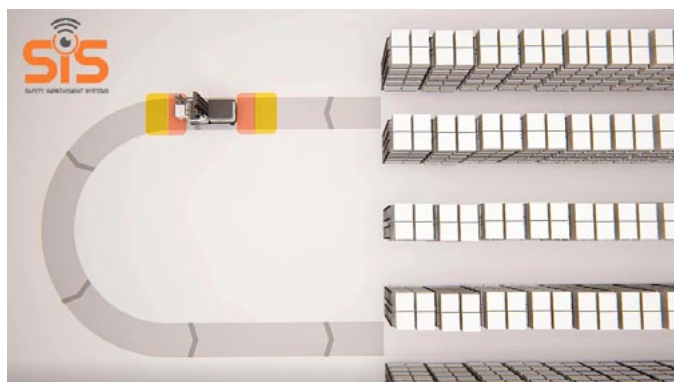
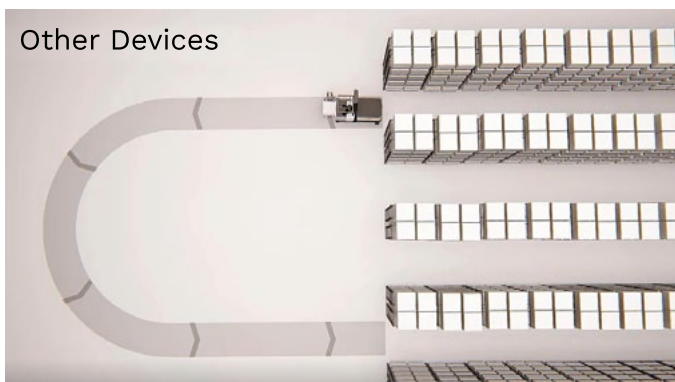

TECHNICAL SPECIFICATIONS

INTUITIVE

Adaptive system self-adapting to environment, inside or outside lanes. Once the operating mode has been chosen (Active with optionals, Active, Passive mode), you will immediately benefit from the simplicity and the efficiency of **Safe&StopVNA**.

ACCURATE

Extremely fast and precise in detecting obstacles (objects or people) on the path.

SIMPLE

A system **as sophisticated as simple** to use.

	Safe&StopVNA	OTHER DEVICES
FLEXIBILITY	Dealer can customize system parameters	Manufacturer only can customize parameters
MAINTENANCE	Dealer	Manufacturer
DETECTION TECHNOLOGY	Solid State LiDAR	Mechanically operated laser system
EXCLUSIVE IN-AISLE USE	No	Yes
INSTALLATION	Dealer	Manufacturer
EXPANDIBILITY	Optionals can be added in a second time	n.a.

TECHNICAL FEATURES

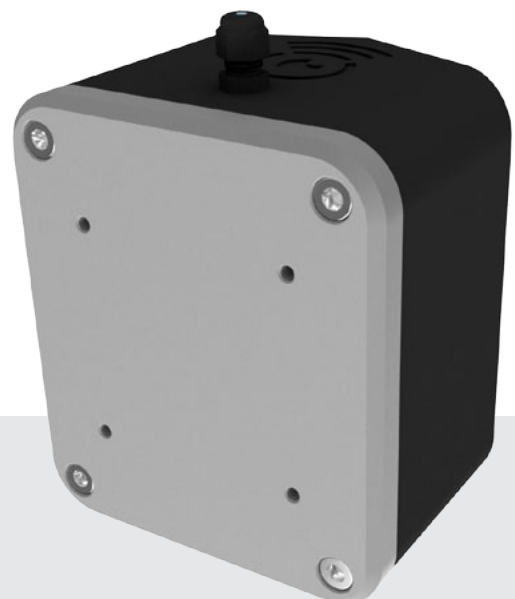
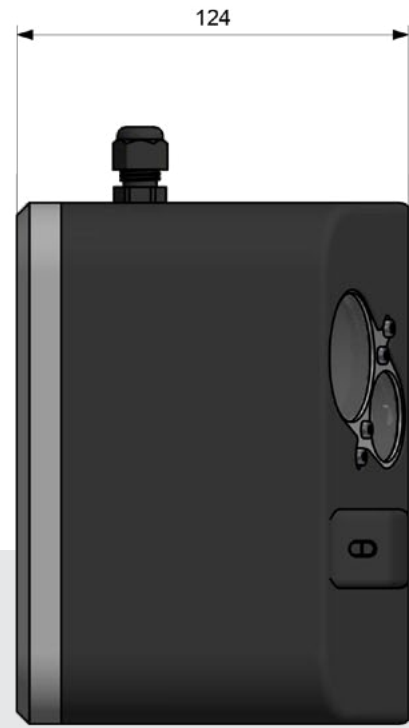
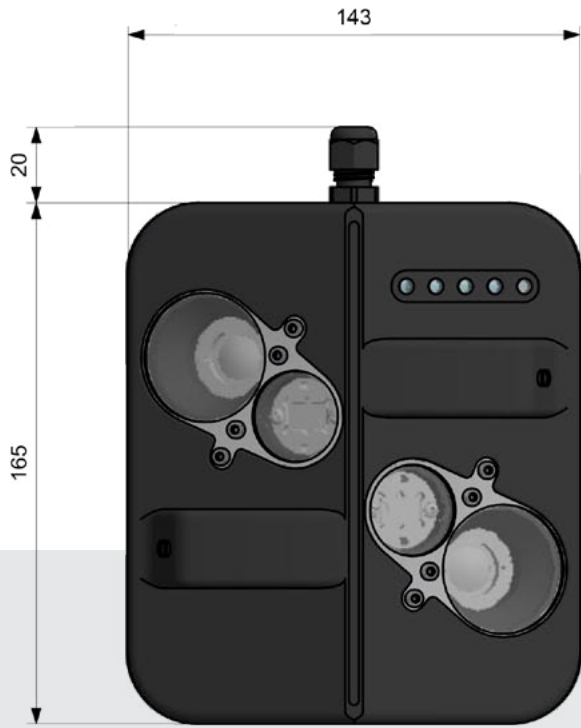

CAN YOU AUTONOMOUSLY SET IT?

Yes, the **dealer can customize the settings**. The end-user must contact the Dealer in order to alter them.

CAN YOU UPDATE FIRMWARE?

Firmware can be directly updated to latest release, in order to always rely on an up-to-date product.

DOES IT NEED A PERIODIC MAINTENANCE?

It is a good practice to run **a periodical cycle of checks**.

WHICH VEHICLES IS IT COMPATIBLE WITH?

The system is designed for maximum flexibility, and **it's adaptable to most vehicles on the market**.

HOW DOES IT BEHAVE IN THE EVENT OF AN OBSTACLE?

In case of obstacle on the path the system, basing on settings, **can visually/acoustically report it and/or intervening on the speed of the truck even stopping it if required**.

Notes



A series of horizontal dotted lines for writing notes, spaced evenly down the page.



SAFETY IMPROVEMENT SYSTEMS

Safety by any means

SIS a division of Cy.Pag. S.p.A.

Via Industria 7 - Morbegno (SO) - Italy

Phone (+39) 0342 605011 - Fax (+39) 0342 614971

email: info@sis-safety.com

web: www.sis-safety.com